



VANMAR
EQUIPMENT CO

WWW.VANMAREQUIPMENT.COM

VMS28MRT
VANMAR EQUIPMENT COMMERCIAL RIDE ON
AUTOMATIC FLOOR SCRUBBER





INTRODUCTION

This manual is furnished with each new model. It provides necessary operation and maintenance instructions.



Read this manual completely and understand the machine before operating or servicing it.

This machine will provide excellent service. However, the best results will be obtained at minimum costs if:

- The machine is operated with reasonable care.
- The machine is maintained regularly - per the machine maintenance instructions provided.
- The machine is maintained with manufacturer supplied or equivalent parts.

To view, print or download manuals online visit www.vanmarequipment.com.

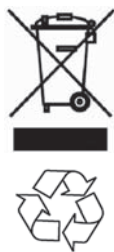

PROTECT THE ENVIRONMENT

Please dispose of packaging materials, used components such as batteries and fluids in an environmentally safe way according to local waste disposal regulations.

Always remember to recycle.

MACHINE DATA

Please fill this form at the time of installation for future references.

Model No.- _____

Serial No.- _____

Installation Date- _____

INTENDED USE

The VMS28MRT is a commercial autoscrubber machine designed to wet scrub both rough and smooth hard surfaces (concrete, tile, stone, synthetic, etc). Typical applications include schools, hospitals / health care facilities, office buildings, and retail centers. Do not use this machine on soil, grass, artificial turf, or carpeted surfaces. This machine is intended for indoor use only. This machine is not intended for use on public roadways. Do not use this machine other than described in this Operator Manual.

VANMAR EQUIPMENT CO.
18866 72nd Avenue South
Kent, Washington 98032

www.vanmarequipment.com

Specifications and parts are subject to change without notice.
Original Instructions. Copyright ©2015-2016 VANMAR EQUIPMENT COMPANY.

SAFETY PRECAUTIONS

IMPORTANT SAFETY INSTRUCTIONS - SAVE THESE INSTRUCTIONS

The following symbols are used throughout this manual as indicated in the descriptions:



WARNING: To warn of hazards or unsafe practices that could result in severe personal injury or death.

FOR SAFETY: To identify actions that must be followed for safe operation of equipment.

The following information signals potentially dangerous conditions to the operator. Know when these conditions can exist. Locate all safety devices on the machine. Report machine damage or faulty operation immediately.



WARNING: Flammable materials can cause an explosion or fire. Do not use flammable materials in tank(s).



WARNING: Flammable materials or reactive metals can cause an explosion or fire. Do not pick up.

FOR SAFETY:

1. Do not operate machine:
 - Unless trained and authorized.
 - Unless operator manual is read and understood.
 - Under the influence of alcohol or drugs
 - While using a cell phone or other types of electronic devices
 - Unless mentally and physically capable of following machine instructions.
 - With brake disabled.
 - If it is not in proper operating condition.
 - In areas where flammable vapors/liquids or combustible dusts are present.
 - In areas that are too dark to safely see the controls or operate the machine.
 - In areas with possible falling objects unless equipped with overhead guard.
2. Before operating the machine:
 - Check machine for fluid leaks.
 - Make sure all safety devices are in place and operate properly.
 - Check brakes and steering for proper operation.
3. When using machine:
 - Use only as described in this manual.
 - Use brakes (if equipped) to stop machine.
 - Go slowly on inclines and slippery surfaces.
 - Reduce speed when turning.
 - Keep all parts of body inside operator station while machine is moving.



- Use care when reversing machine.
 - Never allow children to play on or around machine.
 - Do not carry passengers on machine.
 - Always follow safety and traffic rules.
 - Report machine damage or faulty operation immediately.
 - Follow mixing, handling and disposal instructions on chemical containers.
 - Follow site safety guidelines concerning wet floors.
4. Before leaving or servicing machine:
- Stop on level surface.
 - Turn off machine and remove key.
5. When servicing machine:
- All work must be done with sufficient lighting and visibility.
 - Avoid moving parts. Do not wear loose clothing or jewelry, and secure long hair.
 - Block machine tires before jacking machine up.
 - Jack machine up at designated locations only. Support machine with jack stands.
 - Use hoist or jack that will support the weight of the machine.
 - Do not push or tow the machine on inclines with the brake disabled.
 - Do not power spray or hose off machine near electrical components.
 - Disconnect battery connections before working on machine.
 - Avoid contact with battery acid.
 - Battery installation must be done by trained personnel.
 - All repairs must be performed by a trained service mechanic.
 - Do not modify the machine from its original design.
 - Use VANMAR supplied or approved replacement parts.
 - Wear personal protective equipment as needed and where recommended in this manual.
6. When loading/unloading machine onto/off truck or trailer.
- Drain tanks before loading machine.
 - Lower scrub head and squeegee before strapping down machine.
 - Turn off machine and remove key.
 - Use ramp, truck or trailer that will support the weight of the machine and operator.
 - Do not push the machine onto/off the truck or trailer unless the load height is 15" or less from the ground.
 - Block machine tires.
 - Strap machine down to truck or trailer.



For Safety: wear hearing protection.



For Safety: wear protective gloves.



For Safety: wear eye protection.



For Safety: wear protective dust mask.

Safety labels are marked on appropriate surfaces according to their contents. Please replace the labels in case they are missing, damaged or difficult to recognize.





WARRANTY

VANMAR Equipments full line of commercial cleaning equipment has been manufactured, tested and inspected in accordance with specific engineering requirements. These machines are warranted to be free from defects in workmanship and materials for periods as follows from the date of purchase.

- 7 Years Roto molded components
- 3 Years Parts (excluding wear items)
- 1 Year Labor
- 1 Year AGM Batteries

Travel time for warranty repair is authorized for a period of ninety (90) days following the date of sale to the end user, with a maximum of three (3) hours per claim.

This warranty extends to the original user/purchaser and only when used, operated and maintained in accordance with VANMAREquipments Operating and Maintenance instructions.

This warranty does not apply to certain wear parts and accessories of the machine such as carbon motor brushes, floor brushes or pad drivers, belts, hoses, squeegee blades, etc., nor does it apply to damage or failure caused by improper use, abuse or neglect. Warranty credit or replacement of return parts including motors, switches, etc., is subject to incoming inspection of those items.

To secure repair under this warranty, the following procedure should be taken:

1. After the expiration of the ninety (90) day travel time warranty period, the customer is responsible for warranty travel payment or the inoperative machine or warranted parts must be delivered to the authorized dealer with shipping and delivery charges prepaid. If unable to locate the Dealer, you may contact VANMAR Equipment at the address listed herein for the location of the nearest VANMAR Equipment repair center or agent or for other instructions pertaining to your warranty difficulty.
2. Upon compliance with the above warranty procedure, all warranted repairs will be completed at no additional charge or cost to the user.
3. Only VANMAR Equipment or its authorized dealers and agents may make no charge warranty repairs on this product. All others do so at their own risk.

This warranty limits VANMAR Equipment liability to the repair of the product and/or warranted parts replacement and does not include incidental or consequential damages arising from the use of a VANMAR Equipment machine whether defective or not.

BATTERY WARRANTY In addition to the terms above, any original equipment VANMAR Equipment Battery which becomes unserviceable under normal use within a period of 1 year from date of sale to the original user will be repaired or replaced with one of equal specification at our option, F.O.B. any authorized VANMAR Equipment repair center, with no charge to user, except transportation costs. This warranty is in lieu of all other expressed or implied warranties and is extended to the original purchaser/user.

CONTENTS

| | | | |
|--|----|--|----|
| Introduction..... | 2 | Overload Reset Switch..... | 19 |
| Safety Precautions..... | 3 | Reversing Light..... | 19 |
| Safety Labels..... | 5 | Drain And Clean The Recovery Tank..... | 20 |
| Warranty..... | 6 | Battery Charge..... | 22 |
| Machine Components..... | 8 | Brush, Pad Holder, Cleaning Pad | |
| Controls And Instruments..... | 9 | Replacement..... | 23 |
| Machine Installation..... | 10 | Brush And Cleaning Pad Installation..... | 23 |
| Battery Installation..... | 11 | Squeegee Blade..... | 24 |
| Cleaning Brush & Pads..... | 12 | Replace (Rotate) Squeegee Blad..... | 25 |
| Machine Setup..... | 12 | Adjustment Squeegee..... | 27 |
| Fill solution Tank..... | 13 | Push, Tow and Transport The Machine..... | 28 |
| Machine Operation..... | 14 | Transporting Machine..... | 28 |
| Pre-operational Check..... | 14 | Machine Storage..... | 29 |
| Before Operation..... | 14 | Frost Protection..... | 29 |
| During Operation..... | 16 | Charger LED Indicator..... | 29 |
| Scrubbing Method..... | 16 | Machine Dimensions & Capacity..... | 30 |
| Water Gauge Tube Of Solution Tank..... | 17 | Troubleshooting..... | 32 |
| Recovery Tank Full Indicator..... | 18 | Maintenance Form..... | 33 |
| Battery Electricity Meter..... | 18 | | |



MACHINE COMPONENTS

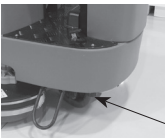
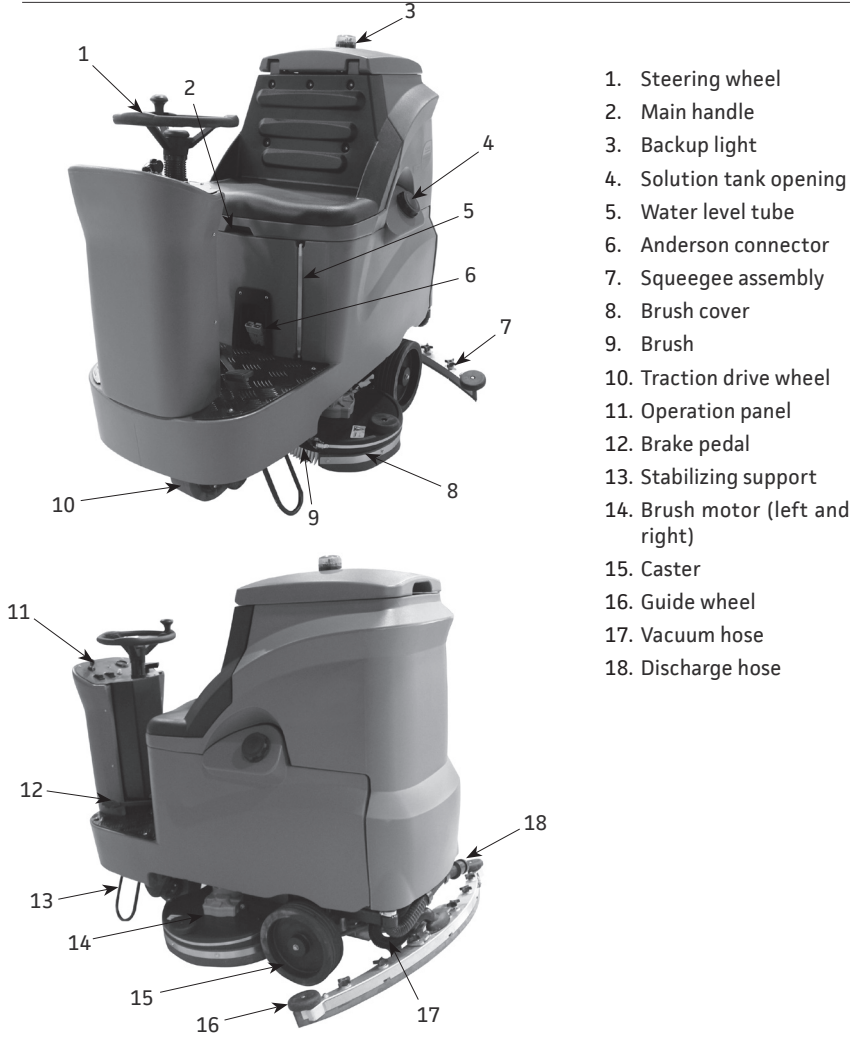

Solution tank drain



Solution tank cover, which is equipped with an air hole to avoid vacuum in the tank

CONTROLS AND INSTRUMENTS

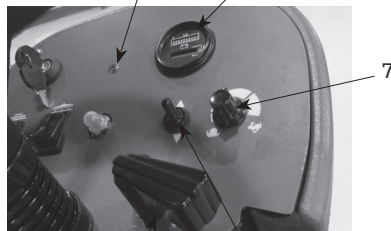
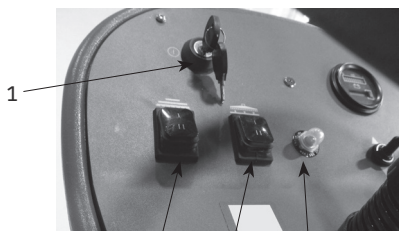







- 1. Main power switch
- 2. Brush motor switch
- 3. Vacuum motor switch
- 4. Overload reset switch
- 5. Fault indicator light
- 6. Battery electricity meter
- 7. Speed control switch
- 8. Forward/reverse switch
- 9. Solution / adjustment control
- 10. Horn



10

Signs on the console

| | | | | | | |
|--|--|---|---|---|---|---|
|  Main Power switch |  Vacuum motor switch |  Brush motor switch |  Forward/Reverse switch |  Speed control switch |  Water level switch |  Horn |
|--|--|---|---|---|---|---|



MACHINE INSTALLATION

Unpacking the machine

1. Remove the outer packing
2. The machine is fastened to the pallet with tie down brackets. Remove the brackets with a Phillips tip with a cordless screwdriver
3. Remove the steel fixed block prior to removing from pallet
4. Using a ram, push the machine backwards down from the pallet
5. Keep the pallet and brackets for any future transport needs

Supplied parts:

- 12V batteries
- 220V, 15A intelligent charger
- Battery installation cables
- Covers and hardware for battery connection
- Squeegee assembly
- 2 malish brushes and 2 malish pad holders

BATTERY INSTALLATION

FOR SAFETY: Wear safety gloves and eye protective devices before working on the batteries or battery connection.

Suggested specifications of batteries:

Two sets of 12V, 120Ah Chil-Wee maintenance free batteries.

1. Stop the machine on a level surface, turn off all the power switches and remove the key.
2. Lift the recovery tank so that battery compartment is accessible. (Figure 1).

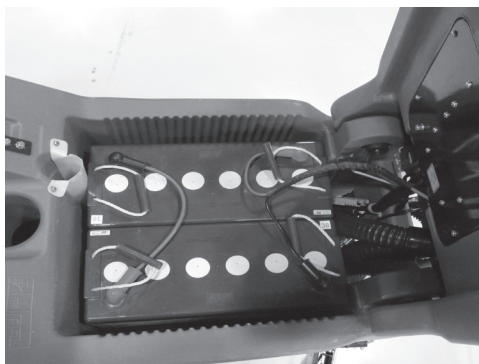

(Figure 1)

3. Fix the batteries into the compartments of battery cabin with care, and place battery connecting posts following the diagram below (Figure 2).
4. Connect battery cables to battery posts following the diagram below (Figure 2) with red cable to the anode post (+) and black cable to cathode post (-).

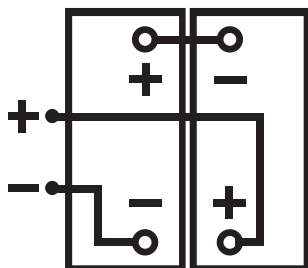

(Figure 2)

CLEANING BRUSH AND PADS

Use appropriate brushes for optimal cleaning effect.

Specifications of recommended brushes and pads are given as follows:

- VMS28MRT Pad holder: 13" Malish pad holder
- VMS28MRT Brush: 13" Malish Brush

MACHINE SETUP

Install squeegee assembly

1. Stop the machine on a level surface.
2. Turn the ON/OFF key switch off.
FOR SAFETY: Stop the machine on a level surface when leaving or servicing it, turn it off and remove the key.
3. Install squeegee to squeegee bracket and tighten the two screw nuts.
4. As is shown in the following figure, connect suction hose with the squeegee assembly.

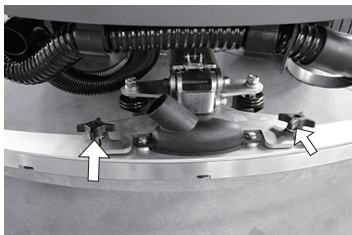
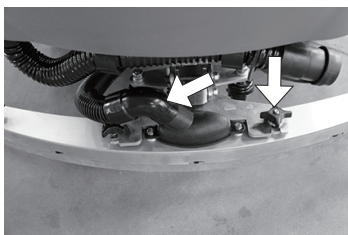

Squeegee assembly has been set up before delivery. For any needed adjustment of squeegee assembly, please refer to Squeegee Blade Adjustment in this manual.

Install Brush/Pad Holder/Cleaning pad

Please refer to Brush, Pad Holder, Cleaning Pad Replacement in this manual for installation of brush or cleaning pad

FILL SOLUTION TANK

FOR SAFETY: Stop the machine on a level surface when leaving or servicing it, turn it off and remove the key.

The water opening for solution tank is located at the left side of machine.

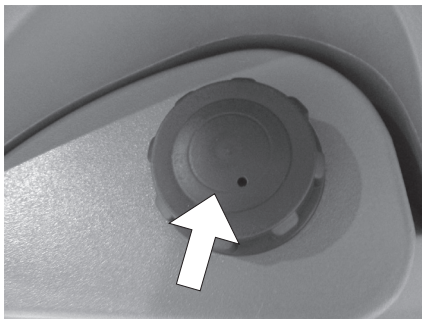

WARNING: DO NOT use flammable materials in the solution tank in case of explosion or fire.

Scrubbing method: Pour the suggested amount of your chosen cleaning detergent / liquid and water into solution tank, according to instruction on the cleaning detergent / liquid container.

NOTE: When filling the solution tank with a bucket, make sure that it is clean. **DO NOT** use the same bucket for filling and draining the machine.

ATTENTION: For conventional scrubbing, only use recommended cleaning detergents. Improper detergents (such as washing powder) can cause damage and will void the manufacturer's warranty.

WARNING: DO NOT use flammable liquids in case of fire or explosion.

FOR SAFETY: Follow the mixing and handling instructions on chemical / solution containers.



MACHINE OPERATION

Pre-operational Check

FOR SAFETY: DO NOT operate the machine before fully reading and understanding this operator manual. Warning: DO NOT operate the machine near or in places with inflammable liquids, gas, or combustible dust in case of fire or explosion.

- Sweep entire floor to remove all loose debris.
- Check battery power indicator (please refer to "Battery Electricity Meter " on page 18).
- Check for the abrasions on pads/brush.
- Check for the abrasions on squeegee blade and make appropriate adjustment.
- Make sure the recovery tank is empty, and that the screen filter has been installed and is clean.
- Check brake and steering for proper operation.
- Check service records to determine maintenance requirements have been kept up to date.

Before Operation

Sweep entire floor to remove all loose debris. Pick up pieces of wire, string ,twine, etc that may be wrapped around the scrubbing brush.

Make a plan for scrubbing in advance. Try to arrange long runs with minimum stopping and starting. Do an entire floor or section at one time.

MACHINE OPERATION

1. Turn the ON/OFF key switch on.
2. Press brush motor switch and vacuum motor switch. This will lower the brush and squeegee assembly down.

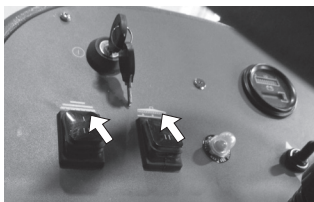

3. Select the preferred scrubbing speed. Turn the solution control to the desired setting. Set direction with forward/reverse switch.

NOTE 1: The machine is in its normal scrubbing state when forward/reverse switch is set to "forward" position.

NOTE 2: Squeegee assembly will rise automatically, vacuum motor will stop and backup light will flash when forward/reverse switch is set to "reverse" position.

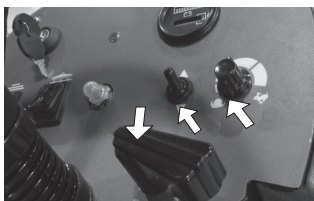

4. Step on the foot pedal to start scrubbing.

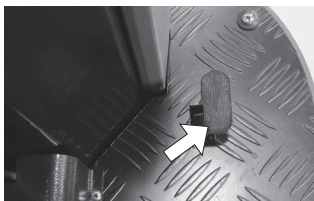



WARNING: Flammable materials or reactive metals can cause explosion or fire. DO NOT pick up with machine.

5. Release the foot pedal to stop the machine. Turn vacuum motor switch off to pull up squeegee. Turn brush motor switch to pull up the brush. Press the brake pedal, pull the manual brake lever to the left, turn the power supply off, and stop the machine.



Brush motor
switch

Vacuum motor
switch



Brake pedal

Manual
brake

Scrubbing foot
switch

6. The brake pedal can be used to control the machine if quicker stopping is needed or if operating on an incline. DO NOT operate machine on inclines exceeding 7%(4°).

FOR SAFETY: Operate slowly on inclines or smooth surfaces when using the machine.

During Operation

Drive a straight path when possible. Avoid bumping into posts or structures or scraping the sides of machine. Overlap the scrub paths for several inches.

Avoid turning the steering wheel substantially since the machine is sensitive to steering wheel rotation. Avoid sudden turning unless its an emergency.

Adjust machine speed and water flow as needed during scrubbing. Keep driving at a moderate speed with minimum water flow.

If poor scrubbing performance is observed, stop scrubbing and refer to troubleshooting.

Scrubbing method

Pour a recommended foam control solution into recovery tank if excessive foam occurs. Otherwise the vacuum motor may be damaged if the foam is sucked into the motor.

Change the pad holder or cleaning pad as necessary for better scrubbing performance.

Observe the battery indicator to ensure there is adequate power for machine to operate.

Remove the key when leaving the machine unattended.

Perform daily maintenance after scrubbing (see Maintenance).

Drive the machine slowly on inclines: press brake pedal to control the machine and turn down speed switch when on declines. Do scrubbing when machine is going upward instead of downward.

FOR SAFETY: Drive slowly when using machine on inclines or smooth surfaces.

DO NOT operate the machine in areas where the temperature exceeds 43°C (110°F). Scrubbing function cannot be used in areas where the temperature is lower than 0°C (32°F).

Maximum rated slope is 7% during operation. Maximum rated incline for transporting the machine is 19.25%.

Water sight gauge tube of Solution Tank

Water sight gauge for solution tank can indicate the real-time water level to ensure proper operation of machine (water level of solution tank is suggested to be kept above half the height of sight gauge tube to guarantee water pressure and water flow).

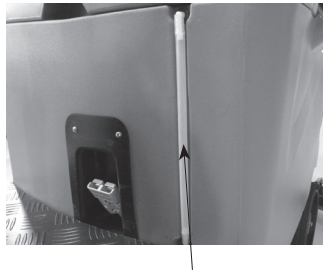

Water sight gauge



Recovery Tank Full Indicator

The recovery tank full indicator will shut off the power supply of vacuum motor without disabling scrubbing functions when the tank is full. Please drain it quickly to guarantee scrubber's proper cleaning operation.

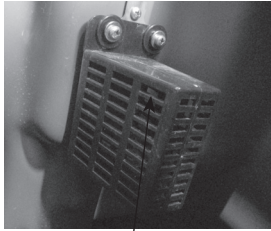

Full indicator shield

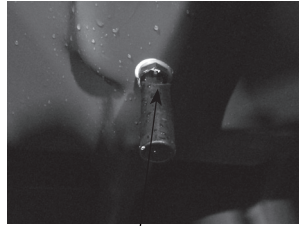

Recovery tank full indicator

Battery Electricity Meter

Battery electricity meter displays battery capacity. When the battery is fully charged, all the indicators will be on and then go out in sequence from right to left.

NOTE: To prolong battery life, charge them after every use.

It is best to stop scrubbing and charge the battery cells when the left light is blinking. Scrubbing operation will automatically shut off to prevent the battery cells from running out. If this happens, charge the battery cells immediately (Figure 14).

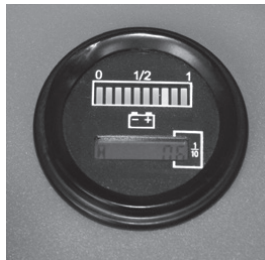

Overload Reset Switch

This model is equipped with a restorable overload protector with a button located on the control panel (Figure 15) to avoid damages to brush motor. When the overload protector is activated and triggers black-out, please check the reason, then press the overload protector button manually after the motor cools down. Contact an authorized service center for machine maintenance if it continues.

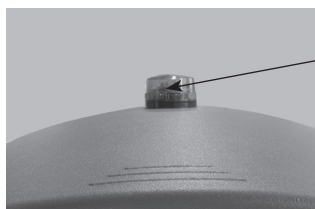

overload reset switch

Reverse Light

reverse light



DRAIN AND CLEAN RECOVERY TANK

When cleaning is finished or when the recovery tank indicator shuts off the power to the vacuum motor, the recovery tank should be drained and cleaned. Then refill solution tank and proceed working.

1. Drive the machine to a solution disposal drain.
2. Turn the ON/OFF key switch off.

FOR SAFETY: Stop the machine on a level surface and turn it off before leaving or servicing.

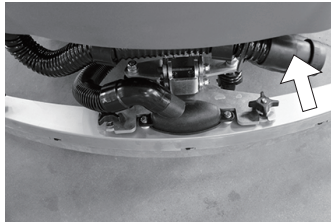

3. Remove the recovery tank drain hose. Remove the plug while holding the hose up. Lower the drain hose slowly for drainage.
4. Lift recovery tank cover; flush the tank inside with clean water.



WARNING: DO NOT use flammable materials in the tank in case of explosion or fire. DO NOT clean the tanks with steam. Excessive heat can damage tanks and components.



5. Clean the full indicator shield inside the recovery tank with clean water.

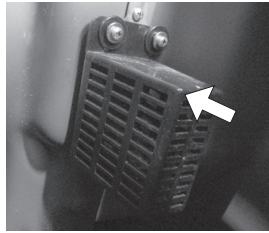

6. Remove the recovery tank drain hose. Remove the plug while holding the hose up. Lower the drain hose slowly to drain.

7. Remove the screen filter counterclockwise, clean it with a piece of wet cloth or a brush carefully if there is stain on it. DO NOT rinse the screen filter directly with pressure.

8. Close recovery tank cover, make sure there are no foreign objects around, as is shown in the following images.



9. Cap the recovery drain hose and fix drain hose back onto machine after draining recovery tank..

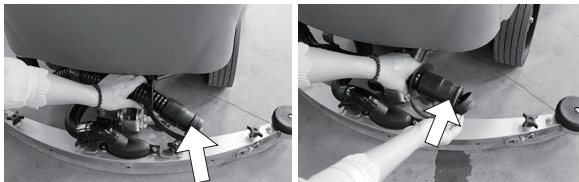



10. Remove solution tank drain hose. Remove solution tank cover from left side and rinse out with water.

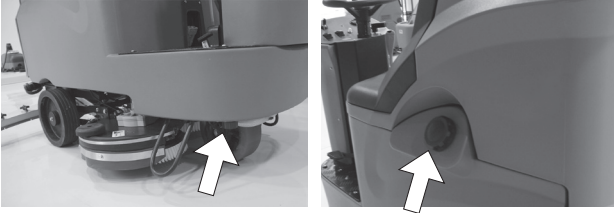

11. Check whether the screen filter is clean. If not, remove the transparent cover counterclockwise with a special wrench, then remove screen filter to clean.

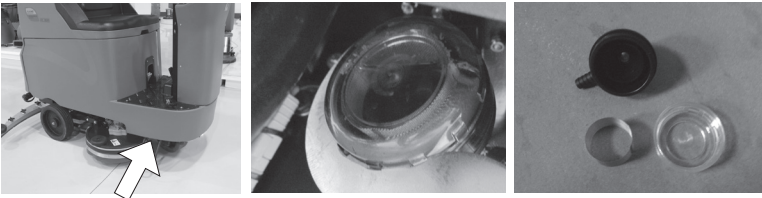

12. Fix solution tank cover and drain hose back onto machine after draining the solution tank.

BATTERY CHARGE

IMPORTANT: Make sure the charger has been set properly based on the certain type of battery before charging. If new, no setup needed.

1. Drive the machine to a flat, dry place.

NOTE: Make sure it is well ventilated.

2. Turn the ON/OFF key switch off.

FOR SAFETY: Stop the machine on a level surface and turn it off before leaving or servicing.

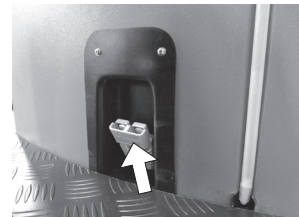

3. Plug the charger connector into the machine's Anderson battery charging connector.

Brush, Pad Holder, Cleaning Pad Replacement

1. Stop the machine on a level surface, make sure the brush assembly is lifted.
2. Turn the ON/OFF key switch to off.

FOR SAFETY: Stop the machine on a level surface and turn it off before storing or servicing..

3. Method for replacing (installing) brush and pad holder: Hold the left brush with both hands and turn it counterclockwise to remove it. Hold the right brush with both hands and turn it clockwise to remove it. Do it opposite when installing the brushes.

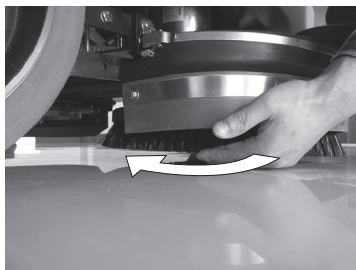

BRUSHES AND CLEADING PADS

The machine is equipped with brushes and pad holders. Check scrub brushes every day for wire or string wrapped around the brush or brush drive hub. Check for brush damage or wear.

FOR SAFETY: Stop the machine on a level surface, turn it off, and remove the key before storing or servicing.

Scrub brushes shall be replaced if a great number of bristles are missing or bristle length is less than 10mm (0.38 inch).

Cleaning pads must be fixed on the pad drive hubs before using. Pad holder is used to secure the pad.

Cleaning pads must be cleaned immediately with soap or water after using. **DO NOT** wash them with a pressure washer.

NOTE: Replace the brushes and pads in whole sets, otherwise one brush or pad will be more aggressive than the other.



As is shown in the figure above: the upper left two pads are used for Model VMS28MRT.

Squeegee Blade

Squeegee blade is used to direct the dirty solution, so that the vacuum motor can suck the solution into recovery tank.

Check the abrasion of squeegee blade every day. If half of the blade is worn out, rotate its direction or replace it with a new one.

Squeegee assembly can be removed from squeegee support during transportation. Unscrew the securing nuts of squeegee assembly counterclockwise to avoid damage.

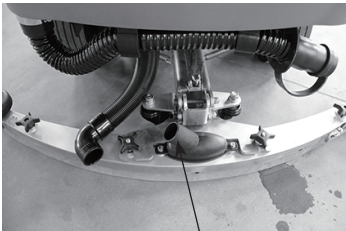

Remove suction hose

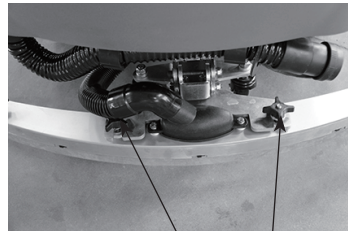

Unscrew the securing nuts counterclockwise

Replace (rotate) Squeegee Blade

1. Stop the machine on a level surface. Make sure the brush motor and squeegee assembly are in the raised position.
2. Turn the ON/OFF key switch off.

FOR SAFETY: Stop the machine on a level surface, turn it off, and remove the key before storing or servicing.

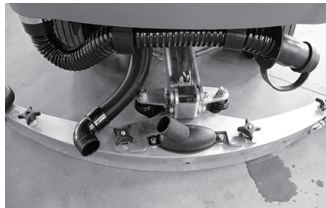

3. Remove squeegee assembly from the machine, release the layer snap joint of the squeegee assembly.

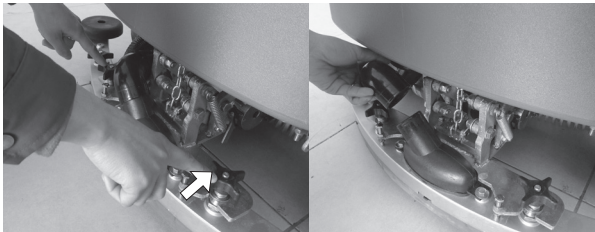

4. Remove squeegee blade from squeegee assembly, tap the two layers lightly with a hammer and remove it from squeegee assembly, then remove the back squeegee blade.

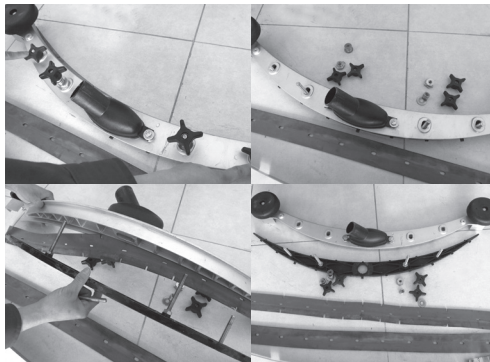



5. Check the squeegee blade for wear before installation. If there is abrasion at either side of the blade, please replace it to the other side. If there is abrasion at both sides, please replace it with a new squeegee blade. The blade with a notch is placed in front of the squeegee assembly, and the other blade without a notch is placed at the back of squeegee assembly. Fix the front blade, install the base-plate of squeegee assembly, then fix the back blade. Note that the hole on squeegee blade should be matched with the flange of squeegee assembly. Then fix the squeegee layer, tighten the snap joint, and tighten the nuts at the base-plate of squeegee assembly, as is shown in the following pictures:

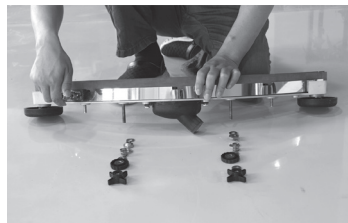
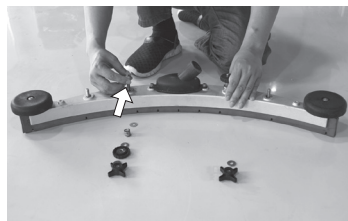
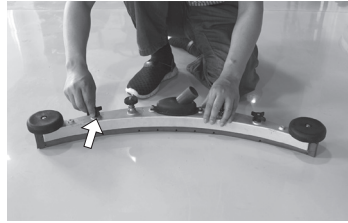
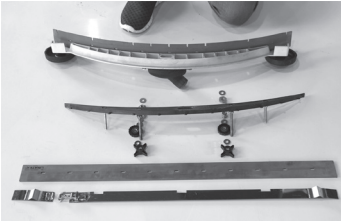

6. Fix the squeegee to squeegee support together with suction hose.

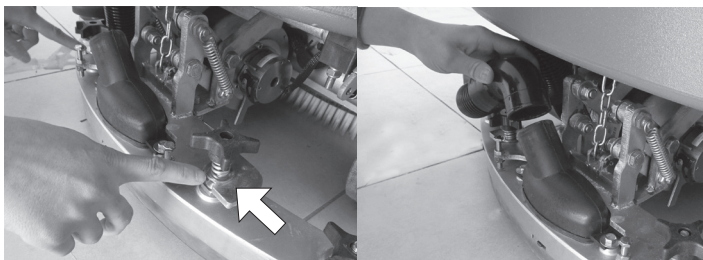

Adjustment Squeegee

Adjust the squeegee at a level surface to make sure the edge of it can totally contact the floor surface.

FOR SAFETY: Stop the machine on a level surface, turn it off, and remove the key before storing or servicing.

1. Stop the machine on a level surface, remove squeegee assembly, turn the squeegee assembly switch on to lay squeegee support down;

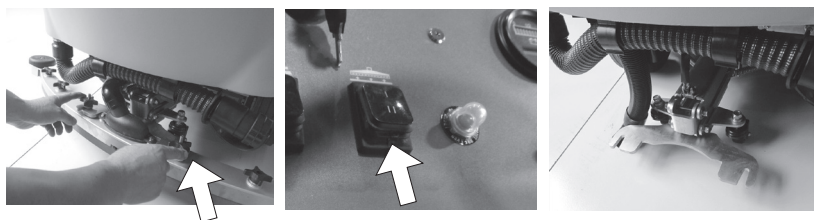

2. When cleaning different types of surfaces, the distance between squeegee and the surface will be different. For example, the distance between squeegee and floor tile, painted floor, and stone floor is: 56cm~57cm; cement floor is: 55cm~56cm. As shown in the following image, adjust the height of universal wheel of squeegee. The height between the squeegee and floor surface is subject to the distance between squeegee support and the floor surface.

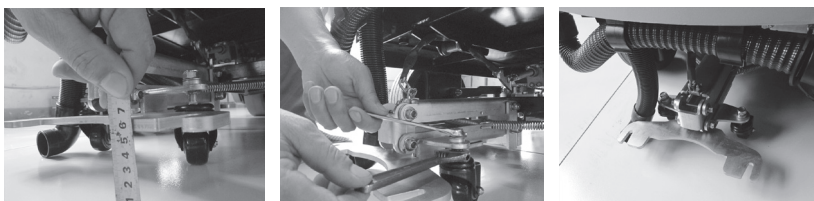

3. Press squeegee switch button to lift squeegee support, fix the squeegee assembly and tighten it. The trial is completed.

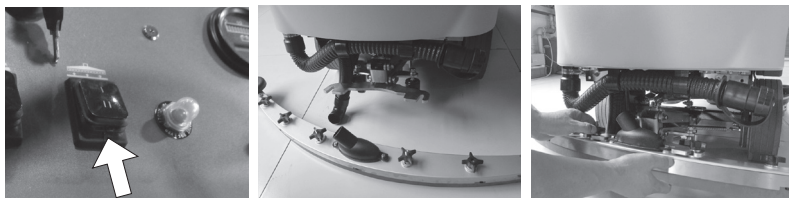

4. After then squeegee is adjusted properly, squeegee blade should bend as is shown in the image below during machine operation.



Push, Tow and Transport the Machine

If the machine is disabled, it can be pushed from the front or rear, but you can only tow it from the front.

FOR SAFETY: DO NOT operate the machine when brake is disabled.

Only push or tow the machine on a level surface at a speed no more than 3.2kp/h (2mph).

DO NOT push or tow the machine at a high speed.

Release the manual brake lever before pushing or towing the machine.

Transporting Machine

Be certain to follow the procedures below when transporting the machine by trailer or truck:

1. Lift the squeegee and brush head.
2. Load/unload the machine using recommended cargo handling apron.
3. Fix the front of the machine close to the front position of truck or trailer. Lower the brush head and squeegee after the machine is fixed tightly.
4. Place a block behind each driving wheel to avoid machine sliding.
5. Fasten the rack of machine with straps to avoid movement. A bracket must be installed on the floor of truck or trailer (Figure 39).

FOR SAFETY: Use the recommended cargo handling apron to load and unload the machine onto and off the truck or trailer. Fasten the machine to the truck or trailer with straps.

Machine Storage

For long time storage of the machine, follow the steps below:

1. Charge the batteries before storage. DO NOT store the machine with battery exhausted. For long-term storage, be sure the batteries are charged every 2-3 months to avoid battery damages due to insufficient voltage.
2. Drain and clean the solution tank and recovery tank.
3. Store the machine at a dry area, keep the squeegee and brush lifted.
4. Open the recovery tank for ventilation.

ATTENTION: Keep the machine away from rain, store it indoor.

5. Follow the frost protection instructions below if the machine is stored at a freezing temperature.

Frost Protection

Add 1 gallons (4L) recreational vehicle (RV) anti-freezing agent to the solution tank without dilution.

FOR SAFETY: Wear goggles to avoid contact with eyes.

ATTENTION: Before operating the machine next time, rinse the solution tank thoroughly to remove the anti-freezing agent.3. Power the machine on, operate solution flow system. When anti-freezing agent flows to scrub head, power the machine off.

Charger LED Indicator

| LED Indicator | Indication Status | Working Status |
|--------------------------------|---|--|
| LED1, LED2 | Blink, fan stops | Pre-charge status [charging time: 3h] |
| LED1, LED2 | Turn RED, fan running | Constant current status [charging time: 7-8h] |
| LED1, LED2 | Turn RED, fan running | Constant voltage status [charging time: 4.5 h] |
| LED1, LED2 | LED1 turns RED, LED2 turns GREEN, Fan stops | Float charging status [charging time: 4.5h] |
| LED1, LED2 | LED1 goes out, LED2 turns GREEN, fan stops | Charge complete |
| Note | | |
| Situations when LED2 turns RED | 1. Load short-circuit | |
| | 2. Reversed connection | |
| | 3. Battery cable short-circuit | |
| | 4. Over-heat—LED2 turns ORANGE | |



Machine Dimensions And Capacity

| | |
|--------------------------|-----------------|
| Model | VMS28MRT |
| Batteries | 12VDC (2 pcs) |
| Batteries Type | AGM |
| Drive System Brush Motor | 400W |
| | |
| Vacuum Motor | 450w (AMETEK) |
| Solution Tank | 18 gallons |
| Recovery Tank | 19 gallons |
| Cleaning Path | 28" |
| Squeegee Width | 40" |
| | |
| Number Of Brushes | 2pcs |
| Propelling Motor | 450w |
| Productivity Per Hour | 48,976 sq ft |
| Dimension | 47" x 22" x 47" |
| Net Weight w/o Batteries | 639 lbs |

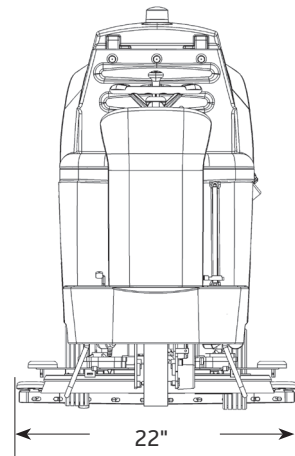
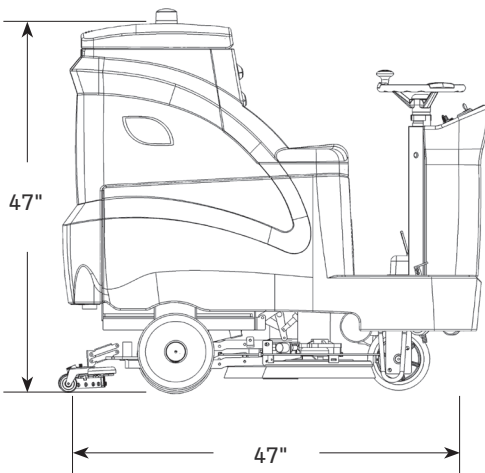
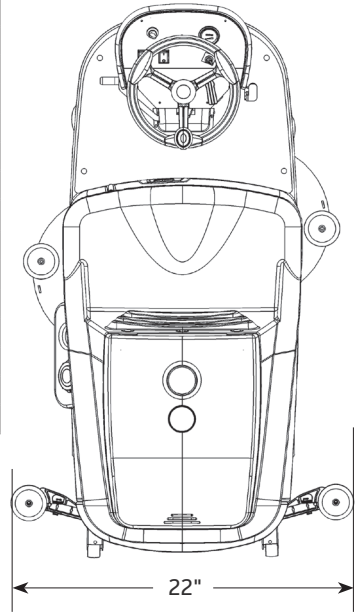



Troubleshooting

| Trouble | Causes | Solutions |
|-------------------------------------|---|---|
| Inadequate suction | Vacuum motor turned off | Turn vacuum motor on |
| | Squeegee blade worn out | Rotate direction or replace squeegee blade |
| | Squeegee out of adjustment | Adjust squeegee |
| | Vacuum hose clogged | Remove the blockage |
| | Screen filter dirty | Clean screen filter |
| | Debris on squeegee | Remove debris |
| | Vacuum hose connected to squeegee disconnected or damaged | Reconnect or replace vacuum hose |
| | Recovery tank not completely closed | Check for obstruction and close cover |
| Vacuum motor failure | Vacuum motor switch turned off | Turn vacuum motor switch on |
| | Recovery tank full | Drain recovery tank |
| | Foam filling recovery tank | Empty recovery tank |
| | | Reduce use of detergent or add a moderate quantity of defoamer |
| | Recovery tank sensor dirty or stuck | Clean or replace sensor |
| Little or no solution flow in brush | Solution tank empty | Refill solution tank |
| | Solution adjustment turned off | Turn on solution adjustment |
| | Magnetic valve damaged | Replace magnetic valve |
| | Solution tank filter clogged | Drain solution tank, remove the filter for cleaning, and then reinstall |
| Poor scrubbing performance | Improper use of detergent or brush | Contact service personnel of |
| | Recovery tank full | Empty recovery tank |
| | Solution tank empty | Refill solution tank |
| | Debris on pad holder or cleaning pad | Remove debris |
| | Scrubbing brush worn out | Replace brushes |
| | Low battery level | Recharge the battery cells until the charger turns off |

Maintenance Form

The following form specifies the person in charge of each procedure.

O=Operator

T=Personnel with specialized training

| Intervals | Person in charge | Check point | Descriptions | Procedures |
|-----------|------------------|-------------|---|---|
| Daily | O | 8 | Brush/pad holder/ cleaning pad | Check the height of brush/pad holder |
| | O | 2 | Recovery tank | Check for damages, abrasion or debris |
| | O | 1 | Lid housing | Do cleaning |
| 50h | O | 7 | Brush blade | Check for damage or abrasion |
| 100h | T | 3 | Recovery tank seal ring | Check for damage or abrasion |
| 200h | T | 4 | Maintenance free battery electrode and wiring | Check and clean |
| 500h | T | 1 | Vacuum motor | Check the motor brush (check it every 100 operating hours after 500-hour initial operation and examination) |
| | T | 6 | Brush motor | Check the motor brush (check it every 100 operating hours after 500-hour initial operation and examination) |
| | T | 9 | Driving motor | Check the motor brush (check it every 100 operating hours after 500-hour initial operation and examination) |
| | T | 5 | Caster | Check damage |

NOTE: More frequent maintenance is needed if the machine works in extremely dusty environment.



VANMAR
EQUIPMENT CO

WWW.VANMAREQUIPMENT.COM